

# INSTALLATION INSTRUCTIONS

540 RPM FRONT  
POWER TAKE-OFF (PTO)  
MFG. NO. 1691351

## KIT PARTS

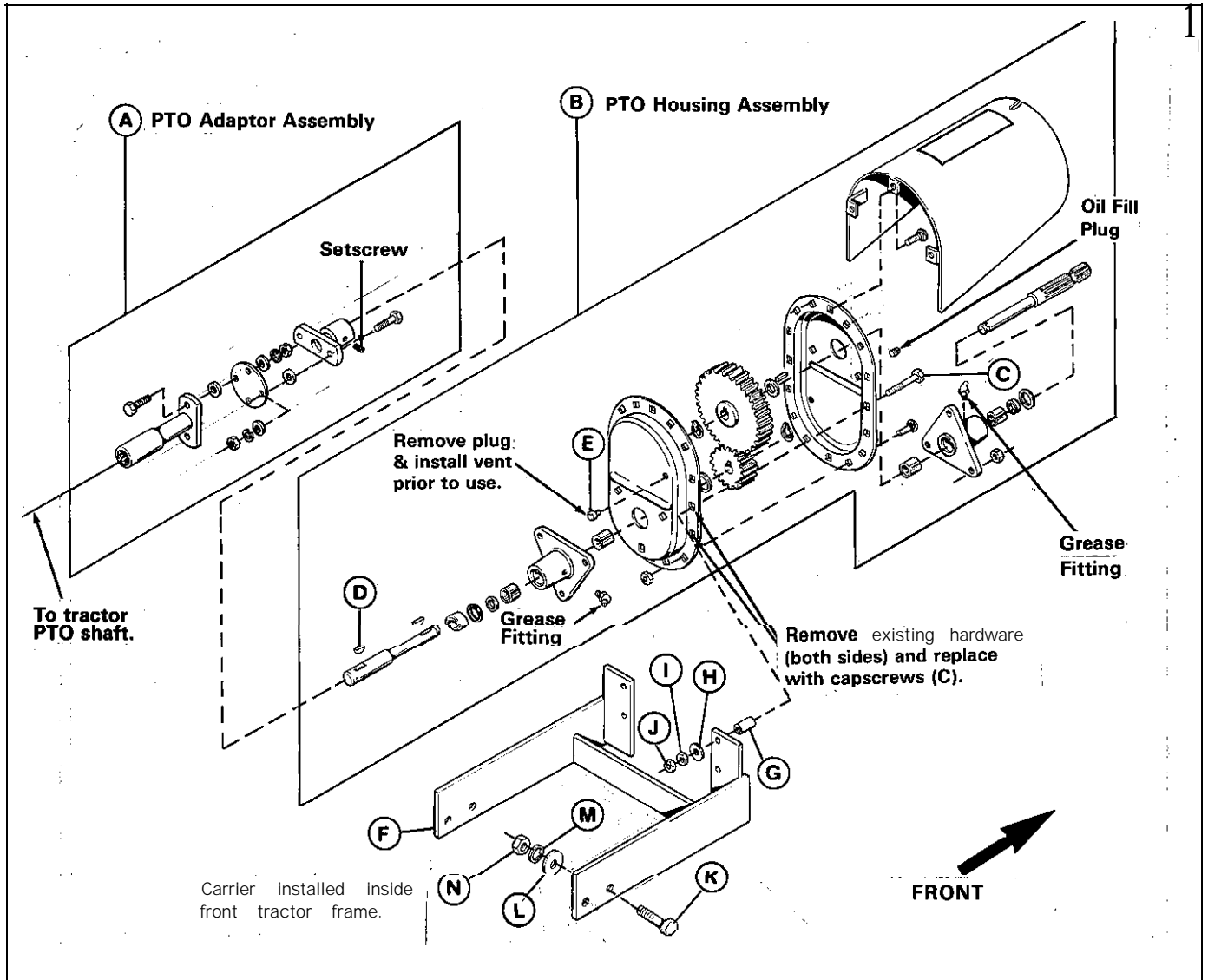

Figure 1.

Item Description	Qty.	Item Description	Qty.	Item Description	Qty.
A PTO Adaptor Assembly	1	F Carrier Frame	1	K Capscrew, 5/8-11x 2 1/4	4
<b>B*</b> PTO Housing Assembly	<b>1</b>	G <b>Spacer</b>	4	L Washer, 5/8	<b>2</b>
C Capscrew, 5/16-18x2-1/4	4	H Washer, 5/16	4	M Lockwasher, 5/8	4
D Key, Woodruff	1	I Nut, Hex, 5/16-18	4	N Nut, 5/8-11	4
E Plug, vent	1	J Nut, Jam, 5/16-18	4		

\*Assemblies A & B have been pre-assembled. Refer to Tractor Attachments Parts Manual for service part numbers.

FORM - 1702133  
PRINTED IN U.S.A.  
6711

## SAFETY DECAL



Located on PTO Shield

## ASSEMBLY

1. Park tractor on a flat, level surface. Shut off engine, **remove** key. and allow all moving parts to stop.

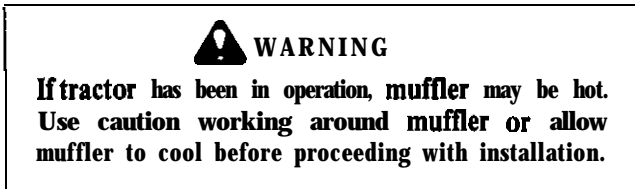

### NOTE

The initial assembly of PTO carrier (F, **figure 1**) to **tractor** frame is easier with hood deck removed from tractor. To **remove** deck:

- a. Tilt deck forward.
  - b. Uncouple headlight wiring harness.
  - c. Remove **two spring clips** and two **clevis** pins.
  - d. Remove hood deck from tractor.
2. Remove PTO shield by removing spring clips and bracket. Store spring clips with bracket.
  3. Install front **capscrews (K)** thru carrier(F) and install washers (L), lockwasher (M), and nuts (N). Leave hardware loose. Large washers (**L**) arc for front slotted frame holes only.
  4. Install carrier onto **tractor** frame and install two **rear capscrews (K)** and hardware (**M, N**). Tighten snug only until PTO is installed.
  5. Apply oil or lubricant to splines of tractor PTO shaft.
  6. Remove existing bolts and nuts from PTO housing at four locations shown in **figure 2**. Install **5/16-18 x 2-1/4 capscrews (C)** from front.
  7. Install spacers (G) on end of **capscrews (C)**.

8. Install woodruff key (D) onto PTO shaft.
9. Install adaptor assembly (A) to housing input shaft. Assembly should **move** easily **over** shaft and key. Rotate PTO adaptor so that setscrew is at top of shaft.
10. Just start PTO adaptor assembly (A) onto tractor PTO shaft. Swivel back and forth in order to align four capscrews (C) and spacers (**G**) with holes in carrier (F).
11. Install washer (H) and hex **nut** (I) and tighten fully. With wrench on nut (I), install jam nut (J) and tighten snug against hex nut.
12. To make **sure** PTO adaptor (A) is properly aligned, lift up on PTO housing (B) with **one** hand while sliding adaptor back and forth. There should be **3/4"**
  - 1" play. When adaptor slides easily between both shafts, hold PTO housing in position and tighten four **capscrews (K)** securing carrier (**F**) to tractor frame.
13. Remove setscrew from PTO adaptor (PTO housing side) and push adaptor all the way towards tractor. When Woodruff key (D) is visible (centered) in setscrew hole, x-install setscrew and tighten.
14. Remove shipping plug from PTO housing (**B**) and check that gear oil is level with plug. Install vent plug (E) when oil level is correct. Use POW **gear** oil as **necessary**.

## REMOVAL & INSTALLATION

1. After initial assembly of PTO adaptor (A), housing (B) and carrier (F), components should be left assembled. Installation and removal can be accomplished with four **capscrews (K)** and mounting hardware (L, M, N).
2. Install **capscrews (K)** only snug initially and repeat alignment procedure (step 12).

## STORAGE & LUBRICATION

1. Store PTO assembly upright on frame to prevent gear oil loss.
2. Check gear oil level every season by **removing** oil till **plug** on front side of PTO housing. Oil should be level with plug opening. Do not till oil to vent plug opening. Refer to **figure 1**.
3. Lubricate grease fittings on each side of PTO housing (B) **every** 25 hours of operation. Apply only 2-3 shots of standard automotive grease.